

REVISIONS			
REV.	DESCRIPTION	DATE	BY
A	INITIAL DRAWING RELEASE (REV 1 SAME AS REV A)	11/15/2018	RGM
B	UPDATE TO CURRENT REVISION	1/12/2021	KC
C	ADD HOLES & SLOTS C/L ALIGNMENT TOLERANCE $\pm .008$	7/13/2021	KC

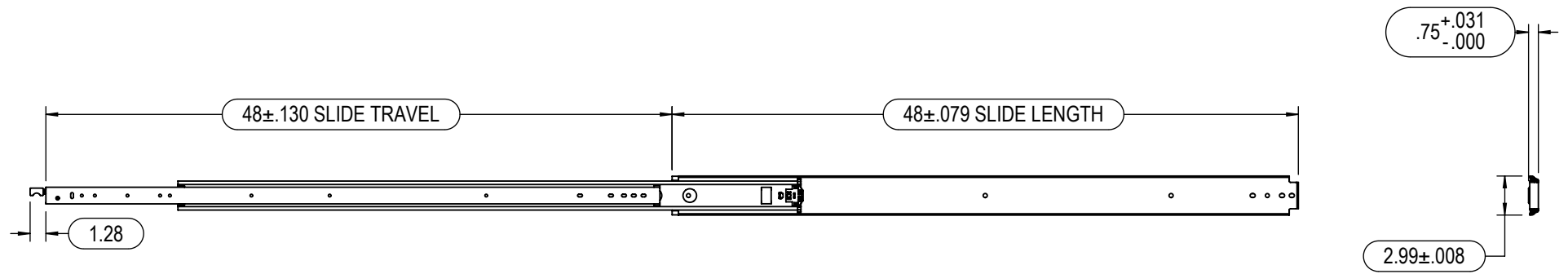

RECOMMENDED
INNER SLIDE MEMBER:
#10 MACHINE OR WOOD PAN HEAD SCREW FOR ALL THRU HOLES AND SLOTTED THRU HOLES.

OUTER SLIDE MEMBER:
1/4 HEX BOLT, #14 PAN HEAD WOOD SCREW FOR ALL THRU HOLES AND SLOTTED THRU HOLES.

SIDE SPACE = .750" - .783"

- NOTES:
- DIMENSIONS APPLY AFTER FINISH.
 - DO NOT SCALE DRAWING.
 - BREAK ALL SHARP EDGES AND REMOVE ALL BURRS.
 - MUST HAVE NO SCRATCHES, DINGS, DENTS OR SURFACE IMPERFECTIONS OTHER THAN SURFACE FINISH REQUIREMENTS.
 - CRITICAL DIMENSIONS ARE INDICATED BY:
 - TO BE INSPECTED TO 2.5 AQL SAMPLING PLAN UNLESS OTHERWISE STATED.
 - ENSURE PACKAGING WILL PROVIDE ADEQUATE PROTECTION DURING TRANSPORT.
 - GEOMETRIC FEATURES NOT DIMENSIONED ARE CONTROLLED BY 3D MODEL.

PART NUMBER: I-DS-3500-48L-5		MATERIAL: STEEL												
DESCRIPTION: 48" 3500 SERIES SLIDE, LEFT		FINISH: ZINC PLATE												
		<h1>RYADON INC.</h1>												
UNLESS OTHERWISE SPECIFIED: DIMENSIONS ARE IN INCHES [mm]		<p style="text-align: center; font-size: small;">PROPRIETARY AND CONFIDENTIAL THE INFORMATION CONTAINED IN THIS DRAWING IS THE SOLE PROPERTY OF RYADON INC. ANY REPRODUCTION IN PART OR AS A WHOLE WITHOUT THE WRITTEN PERMISSION OF RYADON INC. IS PROHIBITED.</p>												
<p style="font-size: x-small;">.XX [X] = ± 0.03 [0.8mm] .XXX [XX] = ± 0.015 [0.38mm] .XXXX [XXX] = ± 0.0080 [0.203mm] FRACTIONAL = $\pm 1/32$" ANGULAR: $\pm 1.0^\circ$</p>	<p>THIRD ANGLE PROJECTION</p>	<p>SIZE</p> <h2>A</h2>	<table border="1" style="width: 100%; text-align: center;"> <tr> <td>ENGR</td> <td>SALES</td> <td>QUALITY</td> <td>REV</td> </tr> <tr> <td>KCHEN</td> <td>MB</td> <td>PN</td> <td rowspan="2" style="font-size: 2em;">C</td> </tr> <tr> <td>DATE</td> <td>7/13/2021</td> <td>7/13/2021</td> </tr> </table>	ENGR	SALES	QUALITY	REV	KCHEN	MB	PN	C	DATE	7/13/2021	7/13/2021
	ENGR	SALES	QUALITY	REV										
	KCHEN	MB	PN	C										
DATE	7/13/2021	7/13/2021												
SCALE: 1:12		DO NOT SCALE												
			SHEET 1 OF 2											

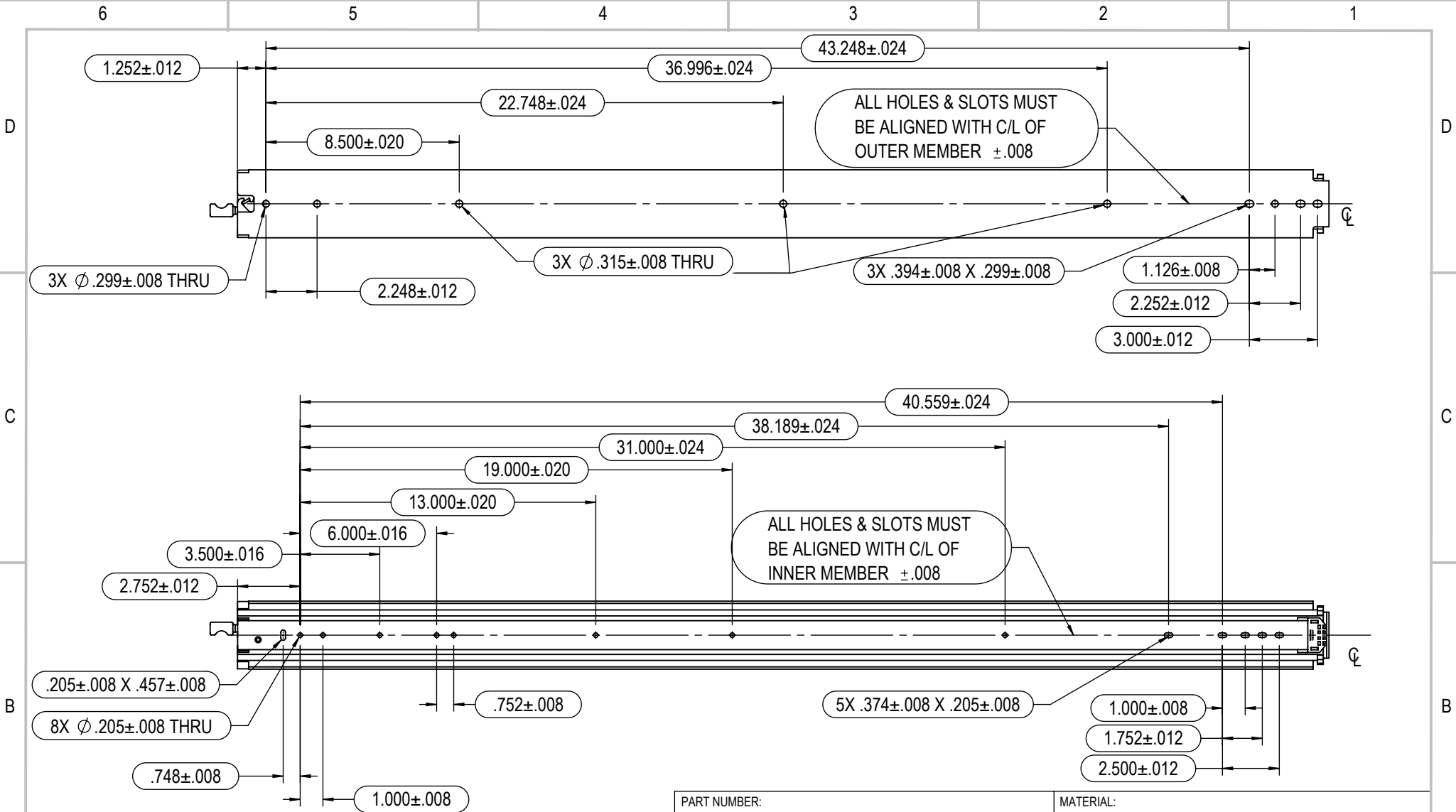

- NOTES:
1. DIMENSIONS APPLY AFTER FINISH.
 2. DO NOT SCALE DRAWING.
 3. BREAK ALL SHARP EDGES AND REMOVE ALL BURRS.
 4. MUST HAVE NO SCRATCHES, DINGS, DENTS OR SURFACE IMPERFECTIONS OTHER THAN SURFACE FINISH REQUIREMENTS.
 5. CRITICAL DIMENSIONS ARE INDICATED BY:
 6. TO BE INSPECTED TO 2.5 AQL SAMPLING PLAN UNLESS OTHERWISE STATED.
 7. ENSURE PACKAGING WILL PROVIDE ADEQUATE PROTECTION DURING TRANSPORT.
 8. GEOMETRIC FEATURES NOT DIMENSIONED ARE CONTROLLED BY 3D MODEL.

PART NUMBER: I-DS-3500-48L-5	MATERIAL: STEEL
DESCRIPTION: 48" 3500 SERIES SLIDE, LEFT	FINISH: ZINC PLATE



RYADON INC.

UNLESS OTHERWISE SPECIFIED: DIMENSIONS ARE IN INCHES [mm] .XX [X] = ± 0.03 [0.8mm] .XXX [XX] = ± 0.015 [0.38mm] .XXXX [XXX] = ± 0.0080 [0.203mm] FRACTIONAL = ± 1/32" ANGULAR = ± 1.0°	PROPRIETARY AND CONFIDENTIAL THE INFORMATION CONTAINED IN THIS DRAWING IS THE SOLE PROPERTY OF RYADON INC. ANY REPRODUCTION IN PART OR AS A WHOLE WITHOUT THE WRITTEN PERMISSION OF RYADON INC. IS PROHIBITED.					
	THIRD ANGLE PROJECTION 	SIZE A	ENGR KCHEN	SALES MB	QUALITY PN	REV C
			DATE 3/6/2020	7/13/2021	7/13/2021	
			SCALE: 1:6	DO NOT SCALE		SHEET 2 OF 2