

REVISIONS			
REV.	DESCRIPTION	DATE	BY
A	INITIAL DRAWING RELEASE (REV 1 SAME AS REV A)	11/15/2018	RGM
B	UPDATE TO CURRENT REVISION	1/12/2021	KC
C	ADD HOLES & SLOTS C/L ALIGNMENT TOLERANCE $\pm .008$	7/13/2021	KC

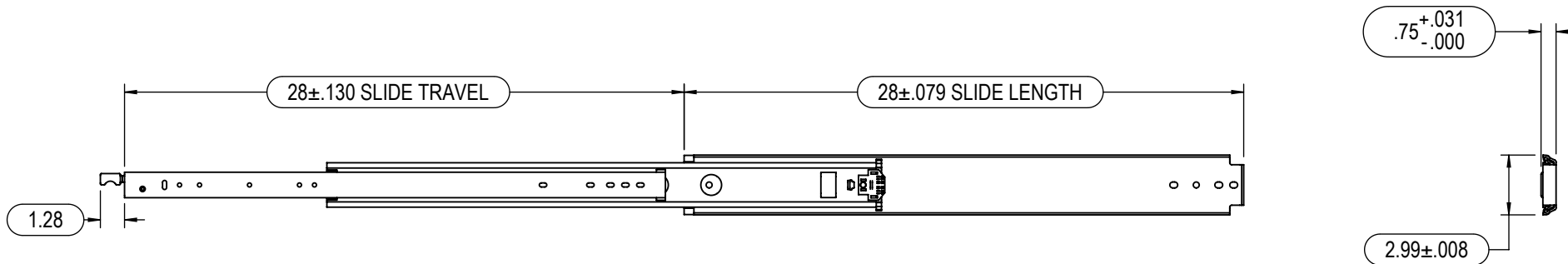

RECOMMENDED

INNER SLIDE MEMBER:

#10 MACHINE OR WOOD PAN HEAD SCREW FOR ALL THRU HOLES AND SLOTTED THRU HOLES.

OUTER SLIDE MEMBER:

1/4 HEX BOLT, #14 PAN HEAD WOOD SCREW FOR ALL THRU HOLES AND SLOTTED THRU HOLES.

SIDE SPACE = .750" - .783"

NOTES:

- DIMENSIONS APPLY AFTER FINISH.
- DO NOT SCALE DRAWING.
- BREAK ALL SHARP EDGES AND REMOVE ALL BURRS.
- MUST HAVE NO SCRATCHES, DINGS, DENTS OR SURFACE IMPERFECTIONS OTHER THAN SURFACE FINISH REQUIREMENTS.
- CRITICAL DIMENSIONS ARE INDICATED BY:
- TO BE INSPECTED TO 2.5 AQL SAMPLING PLAN UNLESS OTHERWISE STATED.
- ENSURE PACKAGING WILL PROVIDE ADEQUATE PROTECTION DURING TRANSPORT.
- GEOMETRIC FEATURES NOT DIMENSIONED ARE CONTROLLED BY 3D MODEL.

PART NUMBER: I-DS-3500-28L-5		MATERIAL: STEEL	
DESCRIPTION: 28" 3500 SERIES SLIDE, LEFT		FINISH: ZINC PLATE	
UNLESS OTHERWISE SPECIFIED: DIMENSIONS ARE IN INCHES [mm]		PROPRIETARY AND CONFIDENTIAL THE INFORMATION CONTAINED IN THIS DRAWING IS THE SOLE PROPERTY OF RYADON INC. ANY REPRODUCTION IN PART OR AS A WHOLE WITHOUT THE WRITTEN PERMISSION OF RYADON INC. IS PROHIBITED.	
THIRD ANGLE PROJECTION 	SIZE A	ENGR	SALES
		NAME	QUALITY
		DATE	REV
SCALE: 1:8		DO NOT SCALE	SHEET 1 OF 2

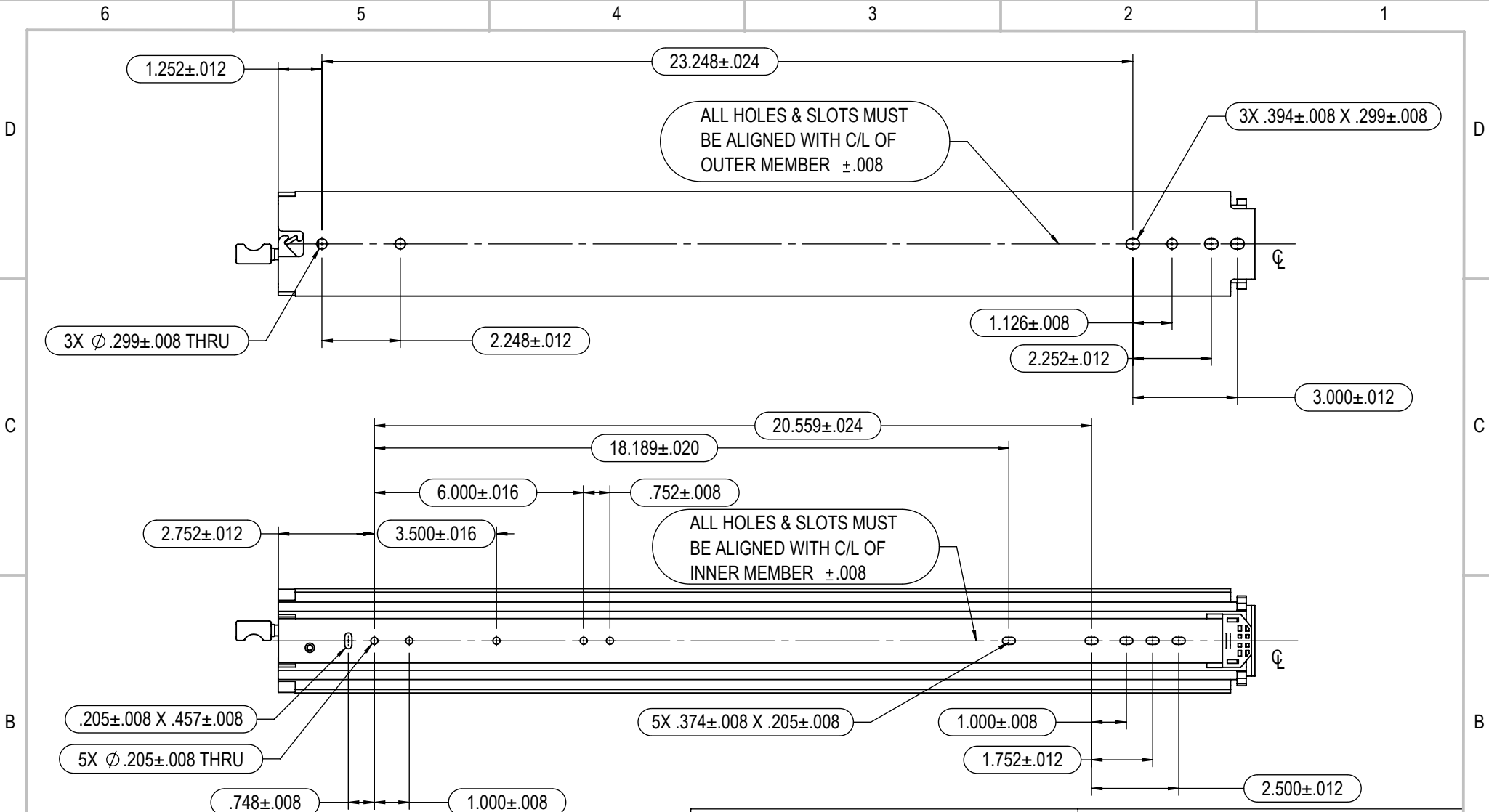

PART NUMBER:	I-DS-3500-28L-5	MATERIAL:	STEEL
DESCRIPTION:	28" 3500 SERIES SLIDE, LEFT	FINISH:	ZINC PLATE



RYADON INC.

UNLESS OTHERWISE SPECIFIED: DIMENSIONS ARE IN INCHES [mm] .XX [X] = ± 0.03 [0.8mm] .XXX [XX] = ± 0.015 [0.38mm] .XXXX [XXX] = ± 0.0080 [0.203mm] FRACTIONAL = ± 1/32" ANGULAR: ± 1.0°	PROPRIETARY AND CONFIDENTIAL THE INFORMATION CONTAINED IN THIS DRAWING IS THE SOLE PROPERTY OF RYADON INC. ANY REPRODUCTION IN PART OR AS A WHOLE WITHOUT THE WRITTEN PERMISSION OF RYADON INC. IS PROHIBITED.				
	THIRD ANGLE PROJECTION	SIZE	ENGR	SALES	QUALITY
		A	KCHEN	MB	PN
	DATE	3/6/2020	7/13/2021	7/13/2021	C
SCALE: 1:4		DO NOT SCALE		SHEET 2 OF 2	

- NOTES:
- DIMENSIONS APPLY AFTER FINISH.
 - DO NOT SCALE DRAWING.
 - BREAK ALL SHARP EDGES AND REMOVE ALL BURRS.
 - MUST HAVE NO SCRATCHES, DINGS, DENTS OR SURFACE IMPERFECTIONS OTHER THAN SURFACE FINISH REQUIREMENTS.
 - CRITICAL DIMENSIONS ARE INDICATED BY:
 - TO BE INSPECTED TO 2.5 AQL SAMPLING PLAN UNLESS OTHERWISE STATED.
 - ENSURE PACKAGING WILL PROVIDE ADEQUATE PROTECTION DURING TRANSPORT.
 - GEOMETRIC FEATURES NOT DIMENSIONED ARE CONTROLLED BY 3D MODEL.