

6

5

4

3

2

1

## REVISIONS

REV.	DESCRIPTION	DATE	BY
A	INITIAL DRAWING RELEASE (REV 1 SAME AS REV A)	11/16/2018	RGM
B	UPDATE TO CURRENT REVISION	2/17/2021	KC

ITEM	QTY.	PART NO.	DESCRIPTION
1	1	I-DS-3500-24R-5	24" 3500 SERIES SLIDE, RIGHT
2	1	I-DS-3300-24	24" 3300 SERIES SLIDE

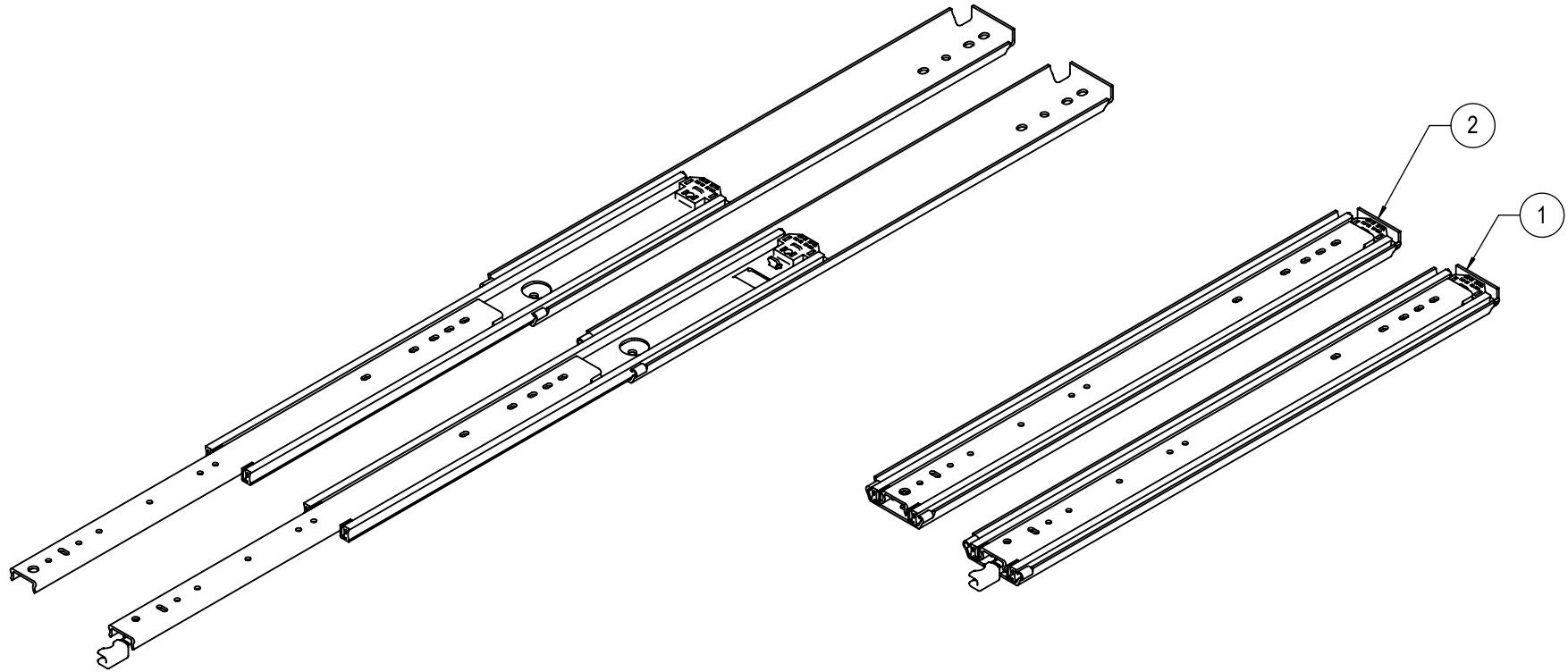

PART NUMBER:

I-DS-3500-24

MATERIAL:

STEEL

DESCRIPTION:

24" 3500 SERIES SLIDE, SET

FINISH:

ZINC PLATE



# RYADON INC.

UNLESS OTHERWISE SPECIFIED:

DIMENSIONS ARE IN INCHES [mm]

.XX [X] = ± 0.03 [0.8mm]  
 .XXX [XX] = ± 0.015 [0.38mm]  
 .XXXX [XXX] = ± 0.0080 [0.203mm]  
 FRACTIONAL = ± 1/32"  
 ANGULAR: ± 1.0°

PROPRIETARY AND CONFIDENTIAL  
 THE INFORMATION CONTAINED IN THIS DRAWING IS THE SOLE PROPERTY OF RYADON INC. ANY REPRODUCTION  
 IN PART OR AS A WHOLE WITHOUT THE WRITTEN PERMISSION OF RYADON INC. IS PROHIBITED.

THIRD ANGLE PROJECTION



SIZE

A

ENGR

NAME

DATE

SCALE: 1:6

SALES

ENGR

DATE

SCALE: 1:6

QUALITY

NAME

DATE

DO NOT SCALE

REV

NAME

DATE

DO NOT SCALE

REV

NAME

DATE

DO NOT SCALE

REV

NAME

DATE

DO NOT SCALE

B

SHEET 1 OF 1

## NOTES:

- DIMENSIONS APPLY AFTER FINISH.
- DO NOT SCALE DRAWING.
- BREAK ALL SHARP EDGES AND REMOVE ALL BURRS.
- MUST HAVE NO SCRATCHES, DINGS, DENTS OR SURFACE IMPERFECTIONS OTHER THAN SURFACE FINISH REQUIREMENTS.
- CRITICAL DIMENSIONS ARE INDICATED BY: 
- TO BE INSPECTED TO 2.5 AQL SAMPLING PLAN UNLESS OTHERWISE STATED.
- ENSURE PACKAGING WILL PROVIDE ADEQUATE PROTECTION DURING TRANSPORT.
- GEOMETRIC FEATURES NOT DIMENSIONED ARE CONTROLLED BY 3D MODEL.

6

5

4

3

2

1