

REVISIONS			
REV.	DESCRIPTION	DATE	BY
E	UPDATED TO CURRENT REVISION	12/10/2019	KC
F	ADD HOLES & SLOTS C/L ALIGNMENT TOLERANCE ± .008	7/13/2021	KC

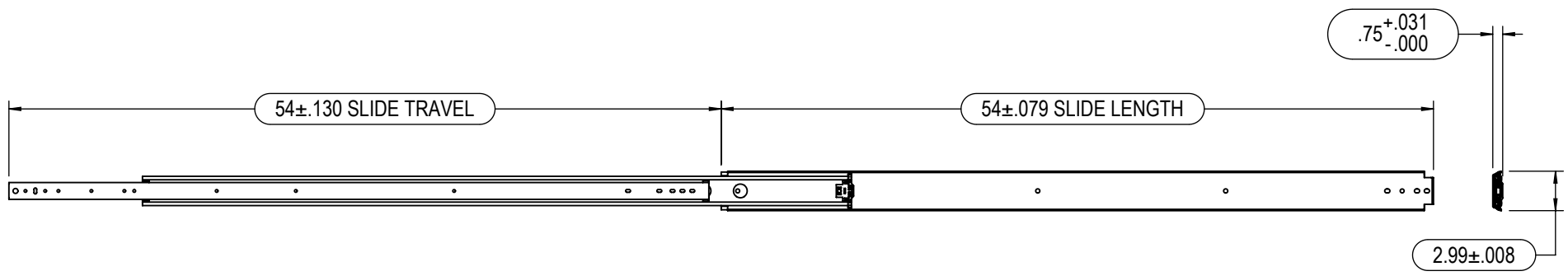



RECOMMENDED
 INNER SLIDE MEMBER:
 #10 MACHINE OR WOOD PAN HEAD SCREW FOR ALL THRU HOLES AND SLOTTED THRU HOLES.

OUTER SLIDE MEMBER:
 1/4 HEX BOLT, #14 PAN HEAD WOOD SCREW FOR ALL THRU HOLES AND SLOTTED THRU HOLES.

SIDE SPACE = .750" - .783"

- NOTES:
1. DIMENSIONS APPLY AFTER FINISH.
 2. DO NOT SCALE DRAWING.
 3. BREAK ALL SHARP EDGES AND REMOVE ALL BURRS.
 4. MUST HAVE NO SCRATCHES, DINGS, DENTS OR SURFACE IMPERFECTIONS OTHER THAN SURFACE FINISH REQUIREMENTS.
 5. CRITICAL DIMENSIONS ARE INDICATED BY:
 6. TO BE INSPECTED TO 2.5 AQL SAMPLING PLAN UNLESS OTHERWISE STATED.
 7. ENSURE PACKAGING WILL PROVIDE ADEQUATE PROTECTION DURING TRANSPORT.
 8. GEOMETRIC FEATURES NOT DIMENSIONED ARE CONTROLLED BY 3D MODEL.

PART NUMBER: I-DS-3300-54		MATERIAL: STEEL		
DESCRIPTION: 54" 3300 SERIES SLIDE		FINISH: ZINC PLATED		
 9001:2015		 RYADON INC.		
UNLESS OTHERWISE SPECIFIED: DIMENSIONS ARE IN INCHES [mm]		PROPRIETARY AND CONFIDENTIAL THE INFORMATION CONTAINED IN THIS DRAWING IS THE SOLE PROPERTY OF RYADON INC. ANY REPRODUCTION IN PART OR AS A WHOLE WITHOUT THE WRITTEN PERMISSION OF RYADON INC. IS PROHIBITED.		
THIRD ANGLE PROJECTION 	SIZE A	ENGR	SALES	REV F
		KCHEN	BW	
		DATE	QUALITY	
SCALE: 1:12		DO NOT SCALE		SHEET 1 OF 2

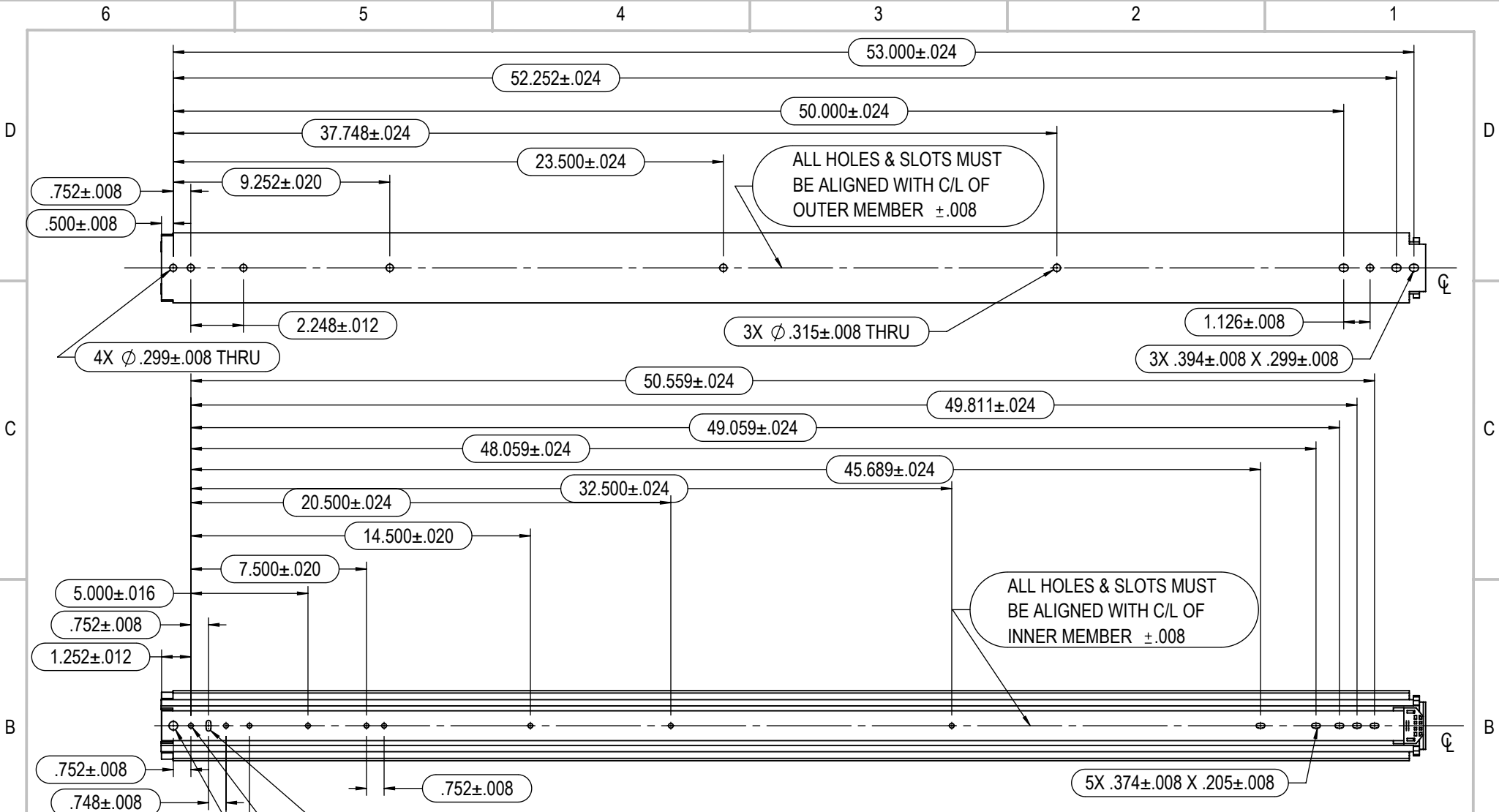

- NOTES:
1. DIMENSIONS APPLY AFTER FINISH.
 2. DO NOT SCALE DRAWING.
 3. BREAK ALL SHARP EDGES AND REMOVE ALL BURRS.
 4. MUST HAVE NO SCRATCHES, DINGS, DENTS OR SURFACE IMPERFECTIONS OTHER THAN SURFACE FINISH REQUIREMENTS.
 5. CRITICAL DIMENSIONS ARE INDICATED BY:
 6. TO BE INSPECTED TO 2.5 AQL SAMPLING PLAN UNLESS OTHERWISE STATED.
 7. ENSURE PACKAGING WILL PROVIDE ADEQUATE PROTECTION DURING TRANSPORT.
 8. GEOMETRIC FEATURES NOT DIMENSIONED ARE CONTROLLED BY 3D MODEL.

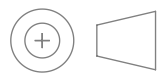
PART NUMBER: I-DS-3300-54		MATERIAL: STEEL	
DESCRIPTION: 54" 3300 SERIES SLIDE		FINISH: ZINC PLATED	
		<h1>RYADON INC.</h1>	
UNLESS OTHERWISE SPECIFIED: DIMENSIONS ARE IN INCHES [mm]		PROPRIETARY AND CONFIDENTIAL THE INFORMATION CONTAINED IN THIS DRAWING IS THE SOLE PROPERTY OF RYADON INC. ANY REPRODUCTION IN PART OR AS A WHOLE WITHOUT THE WRITTEN PERMISSION OF RYADON INC. IS PROHIBITED.	
THIRD ANGLE PROJECTION 	SIZE <h2>A</h2>	ENGR	KCHEN
		NAME	KCHEN
		DATE	12/10/2019
		SALES	QUALITY
		SCALE: 1:6	DO NOT SCALE
		REV	F
		SHEET 2 OF 2	