

6 5 4 3 2 1

REVISIONS			
REV.	DESCRIPTION	DATE	BY
E	UPDATED TO CURRENT REVISION	12/9/2019	KC
F	ADD HOLES & SLOTS C/L ALIGNMENT TOLERANCE ± .008	7/13/2021	KC

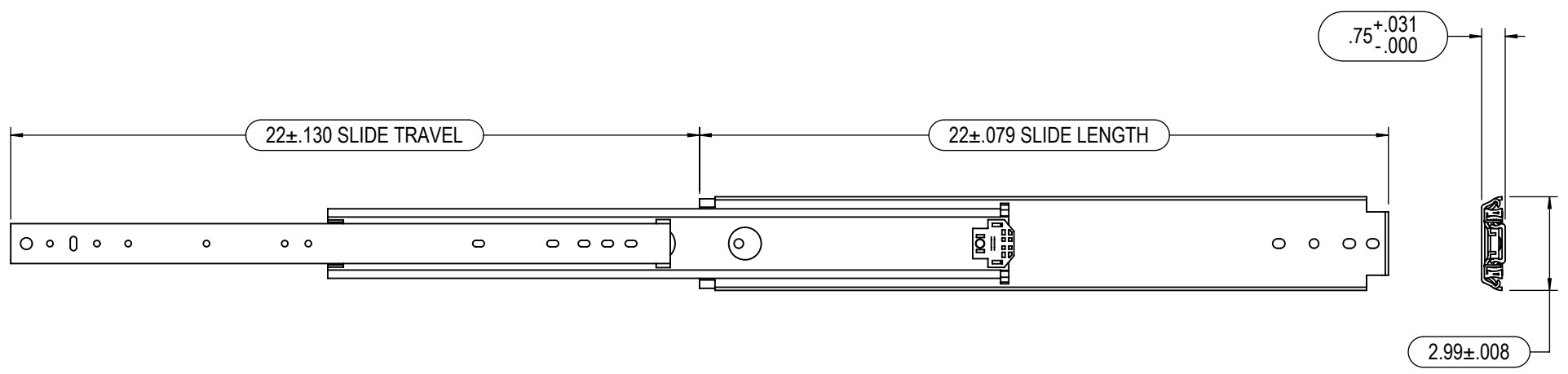

RECOMMENDED
INNER SLIDE MEMBER:
#10 MACHINE OR WOOD PAN HEAD SCREW FOR ALL THRU HOLES AND SLOTTED THRU HOLES.

OUTER SLIDE MEMBER:
1/4 HEX BOLT, #14 PAN HEAD WOOD SCREW FOR ALL THRU HOLES AND SLOTTED THRU HOLES.

SIDE SPACE = .750" - .783"

- NOTES:
1. DIMENSIONS APPLY AFTER FINISH.
 2. DO NOT SCALE DRAWING.
 3. BREAK ALL SHARP EDGES AND REMOVE ALL BURRS.
 4. MUST HAVE NO SCRATCHES, DINGS, DENTS OR SURFACE IMPERFECTIONS OTHER THAN SURFACE FINISH REQUIREMENTS.
 5. CRITICAL DIMENSIONS ARE INDICATED BY:
 6. TO BE INSPECTED TO 2.5 AQL SAMPLING PLAN UNLESS OTHERWISE STATED.
 7. ENSURE PACKAGING WILL PROVIDE ADEQUATE PROTECTION DURING TRANSPORT.
 8. GEOMETRIC FEATURES NOT DIMENSIONED ARE CONTROLLED BY 3D MODEL.

PART NUMBER: I-DS-3300-22		MATERIAL: STEEL					
DESCRIPTION: 22" 3300 SERIES SLIDE		FINISH: ZINC PLATED					
		<h1>RYADON INC.</h1>					
UNLESS OTHERWISE SPECIFIED: DIMENSIONS ARE IN INCHES [mm]		<small>PROPRIETARY AND CONFIDENTIAL</small> THE INFORMATION CONTAINED IN THIS DRAWING IS THE SOLE PROPERTY OF RYADON INC. ANY REPRODUCTION IN PART OR AS A WHOLE WITHOUT THE WRITTEN PERMISSION OF RYADON INC. IS PROHIBITED.					
.XX [X] = ± 0.03 [0.8mm] .XXX [XX] = ± 0.015 [0.38mm] .XXXX [XXX] = ± 0.0080 [0.203mm] FRACTIONAL = ± 1/32" ANGULAR: ± 1.0°		THIRD ANGLE PROJECTION 	SIZE <h2>A</h2>	ENGR NAME KCHEN DATE 12/10/2019	SALES BW 7/13/2021	QUALITY PN 7/13/2021	REV <h2>F</h2>
SCALE: 1:5			DO NOT SCALE		SHEET 1 OF 2		

6 5 4 3 2 1

D

D

C

C

B

B

A

A

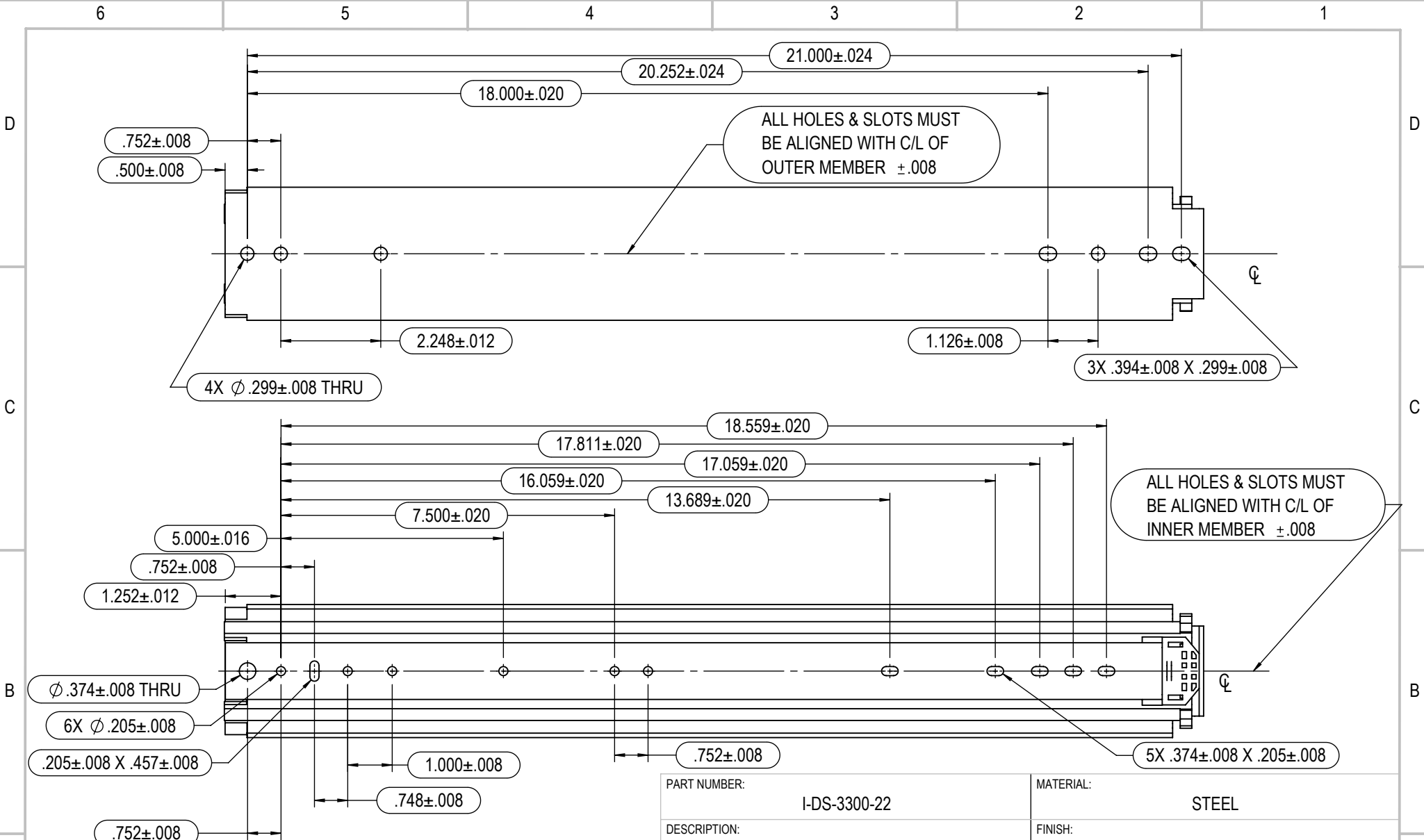

PART NUMBER:	I-DS-3300-22	MATERIAL:	STEEL
DESCRIPTION:	22" 3300 SERIES SLIDE	FINISH:	ZINC PLATED

RYADON INC.

UNLESS OTHERWISE SPECIFIED: DIMENSIONS ARE IN INCHES [mm] .XX [X] = ± 0.03 [0.8mm] .XXX [XX] = ± 0.015 [0.38mm] .XXXX [XXX] = ± 0.0080 [0.203mm] FRACTIONAL = ± 1/32" ANGULAR = ± 1.0°	THIRD ANGLE PROJECTION				A	ENGR	SALES	QUALITY	REV
	NAME		KCHEN					F	
	DATE		12/10/2019			SCALE: 1:3	DO NOT SCALE	SHEET 2 OF 2	

- NOTES:
1. DIMENSIONS APPLY AFTER FINISH.
 2. DO NOT SCALE DRAWING.
 3. BREAK ALL SHARP EDGES AND REMOVE ALL BURRS.
 4. MUST HAVE NO SCRATCHES, DINGS, DENTS OR SURFACE IMPERFECTIONS OTHER THAN SURFACE FINISH REQUIREMENTS.
 5. CRITICAL DIMENSIONS ARE INDICATED BY:
 6. TO BE INSPECTED TO 2.5 AQL SAMPLING PLAN UNLESS OTHERWISE STATED.
 7. ENSURE PACKAGING WILL PROVIDE ADEQUATE PROTECTION DURING TRANSPORT.
 8. GEOMETRIC FEATURES NOT DIMENSIONED ARE CONTROLLED BY 3D MODEL.