

REVISIONS			
REV.	DESCRIPTION	DATE	BY
E	UPDATED TO CURRENT REVISION	12/9/2019	KC
F	ADD HOLES & SLOTS C/L ALIGNMENT TOLERANCE $\pm .008$	7/13/2021	KC

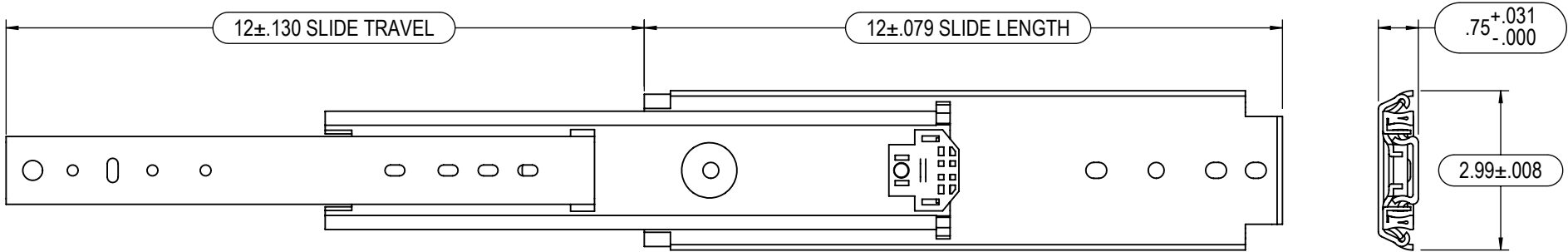

RECOMMENDED  
 INNER SLIDE MEMBER:  
 #10 MACHINE OR WOOD PAN HEAD SCREW FOR ALL THRU HOLES AND SLOTTED THRU HOLES.

OUTER SLIDE MEMBER:  
 1/4 HEX BOLT, #14 PAN HEAD WOOD SCREW FOR ALL THRU HOLES AND SLOTTED THRU HOLES.

SIDE SPACE = .750" - .783"

- NOTES:
1. DIMENSIONS APPLY AFTER FINISH.
  2. DO NOT SCALE DRAWING.
  3. BREAK ALL SHARP EDGES AND REMOVE ALL BURRS.
  4. MUST HAVE NO SCRATCHES, DINGS, DENTS OR SURFACE IMPERFECTIONS OTHER THAN SURFACE FINISH REQUIREMENTS.
  5. CRITICAL DIMENSIONS ARE INDICATED BY:
  6. TO BE INSPECTED TO 2.5 AQL SAMPLING PLAN UNLESS OTHERWISE STATED.
  7. ENSURE PACKAGING WILL PROVIDE ADEQUATE PROTECTION DURING TRANSPORT.
  8. GEOMETRIC FEATURES NOT DIMENSIONED ARE CONTROLLED BY 3D MODEL.

PART NUMBER: <b>I-DS-3300-12</b>		MATERIAL: <b>STEEL</b>	
DESCRIPTION: <b>12" 3300 SERIES SLIDE</b>		FINISH: <b>ZINC PLATED</b>	
		<h1>RYADON INC.</h1>	
UNLESS OTHERWISE SPECIFIED: DIMENSIONS ARE IN INCHES [mm]		PROPRIETARY AND CONFIDENTIAL THE INFORMATION CONTAINED IN THIS DRAWING IS THE SOLE PROPERTY OF RYADON INC. ANY REPRODUCTION IN PART OR AS A WHOLE WITHOUT THE WRITTEN PERMISSION OF RYADON INC. IS PROHIBITED.	
THIRD ANGLE PROJECTION 	SIZE <b>A</b>	ENGR KCHEN	SALES BW
	NAME	QUALITY PN	REV <b>F</b>
	DATE 12/10/2019	7/13/2021	7/13/2021
SCALE: 1:3		DO NOT SCALE	
			SHEET 1 OF 2

XX [X] =  $\pm 0.03$  [0.8mm]  
 .XXX [XX] =  $\pm 0.015$  [0.38mm]  
 .XXXX [XXX] =  $\pm 0.0080$  [0.203mm]  
 FRACTIONAL =  $\pm 1/32$ "  
 ANGULAR:  $\pm 1.0^\circ$

D

C

B

A

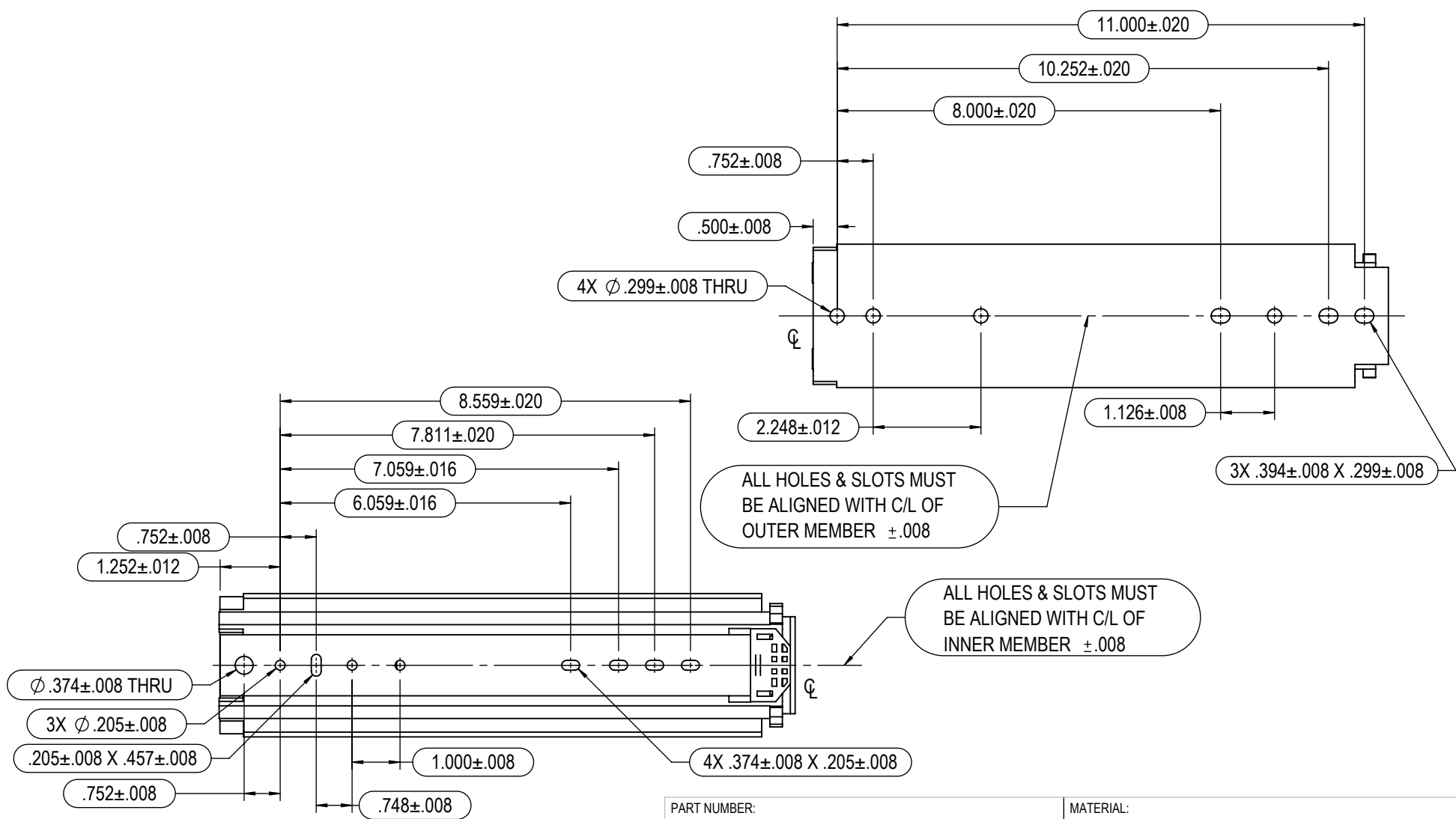

- NOTES:
1. DIMENSIONS APPLY AFTER FINISH.
  2. DO NOT SCALE DRAWING.
  3. BREAK ALL SHARP EDGES AND REMOVE ALL BURRS.
  4. MUST HAVE NO SCRATCHES, DINGS, DENTS OR SURFACE IMPERFECTIONS OTHER THAN SURFACE FINISH REQUIREMENTS.
  5. CRITICAL DIMENSIONS ARE INDICATED BY:
  6. TO BE INSPECTED TO 2.5 AQL SAMPLING PLAN UNLESS OTHERWISE STATED.
  7. ENSURE PACKAGING WILL PROVIDE ADEQUATE PROTECTION DURING TRANSPORT.
  8. GEOMETRIC FEATURES NOT DIMENSIONED ARE CONTROLLED BY 3D MODEL.

PART NUMBER:	I-DS-3300-12	MATERIAL:	STEEL
DESCRIPTION:	12" 3300 SERIES SLIDE	FINISH:	ZINC PLATED



# RYADON INC.

UNLESS OTHERWISE SPECIFIED: DIMENSIONS ARE IN INCHES [mm] .XX [X] = ± 0.03 [0.8mm] .XXX [XX] = ± 0.015 [0.38mm] .XXXX [XXX] = ± 0.0080 [0.203mm] FRACTIONAL = ± 1/32" ANGULAR: ± 1.0°	THIRD ANGLE PROJECTION					SIZE <b>A</b>	ENGR	SALES	QUALITY	REV
	+		□		NAME		KCHEN			<b>F</b>
					DATE		12/10/2019			
					SCALE: 1:3			DO NOT SCALE	SHEET 2 OF 2	